

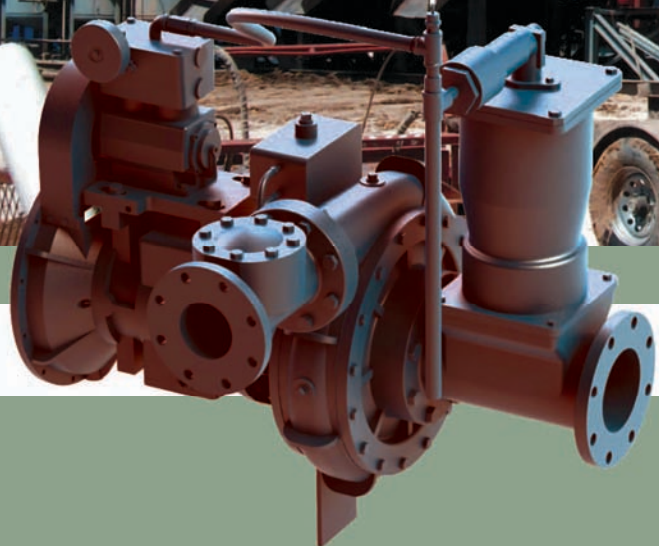

# CORNELL PUMP COMPANY

# WATER TRANSFER

## HYDRAULIC FRACTURING



EFFICIENT BY DESIGN



# HYDRAULIC FRACKING



## SETTING THE STANDARD FOR FRACKING

Cornell's pumps are designed and engineered for the most rugged and demanding installations. From the Antrim to Woodford Shales, Cornell pumps have exceeded operating expectations, and provided hydraulic fracturing companies unprecedented uptime, reliability, and efficiency. Cornell pumps have been designed and manufactured to exacting standards since 1946 in Portland, OR. We supply pumps for not only oil and gas exploration/extraction, but also mining, municipal, agricultural, food processing, industrial, and rental applications.

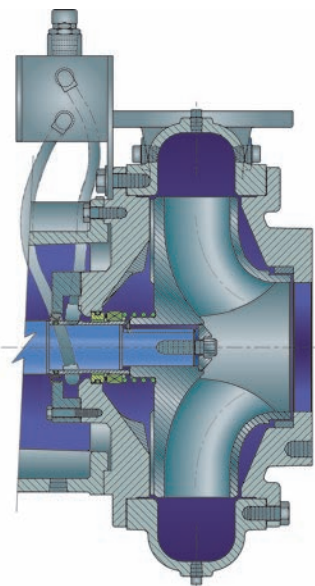

### CYCLOSEAL®

Cornell's Cycloseal® design, with its unique deflector vanes, works with the impeller back vanes to create a cyclonic-action. This action removes solids and abrasive material from the seal area while purging air and gas pockets - extending seal life and eliminating any need for venting or water flush. The Cycloseal® design extends seal life up to three times that of a conventional mechanical seal. Longer seal life translates into less down time and lower maintenance costs.

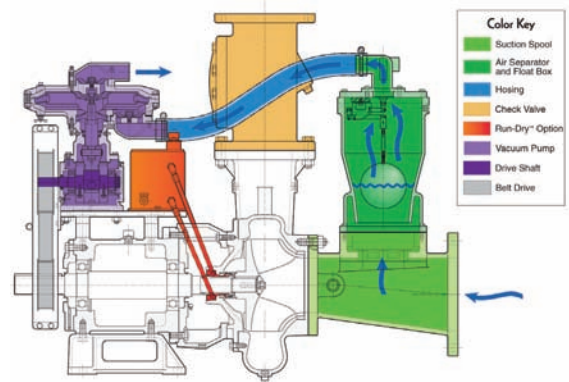

### REDI-PRIME®

Cornell's patented priming and repriming system allows your pumps to work properly, unattended. Redi-Prime® pumps are designed with oversized suction to provide more flow, reduce suction friction losses, and make air liquid mixtures with ease.



# HYDRAULIC FRACKING

## ENERGY EFFICIENT

With fuel prices at record levels, Cornell pump's high energy efficiency stretch your dollar on-site further. Cornell manufactures more than 65 clear liquid and non-clog pumps that meet or exceed optimum efficiency standards for centrifugal pumps. We have numerous examples of Cornell pumps saving tens of thousands of dollars per year on job sites through increased efficiency. That's money you can put back into your operation!

## SOLIDS HANDLING

Cornell's two- and three-port enclosed impellers are designed to handle large solids and maintain exceptional hydraulic efficiencies. Cornell's Delta™ style impeller is specifically designed for handling stringy materials and heavy sludge for low- to medium-head applications. The three- or four-vane, semi-open impeller generates a cutting action designed to handle concentrated slurries for high head applications.

### FEATURES

- Heads up to 800 feet possible
- Valve eliminates any liquid carry-over
- Suction lifts up to 28 feet
- Hardened Iron extends life of pump
- Industry leading two-year warranty

### BENEFITS

- Fully automated priming and self-priming, dry-run pumps
- Handles Air/liquid mixtures with ease
- Patented Cycloseal®, Redi-Prime®, and Run-Dry™ options
- Handles Large sized Solid
- High suction lift capabilities up to 28 feet
- Up to 7000 GPM flow



# FRACKING PUMPS



Cornell Pump Company produces pumps with extra heavy wall thickness, featuring industry leading efficiency. We produce water distribution pumps in most popular sizes from 3" to 8", with up to 28 feet of suction, 475 feet of head and 7000 GPM flow. We feature the most popular pumps for Fracking with our 3HC, 4HC, 6NHTA, 6NHTB 8H, 8NHTA, 8NHTH pumps. Cornell Quality construction shines through.

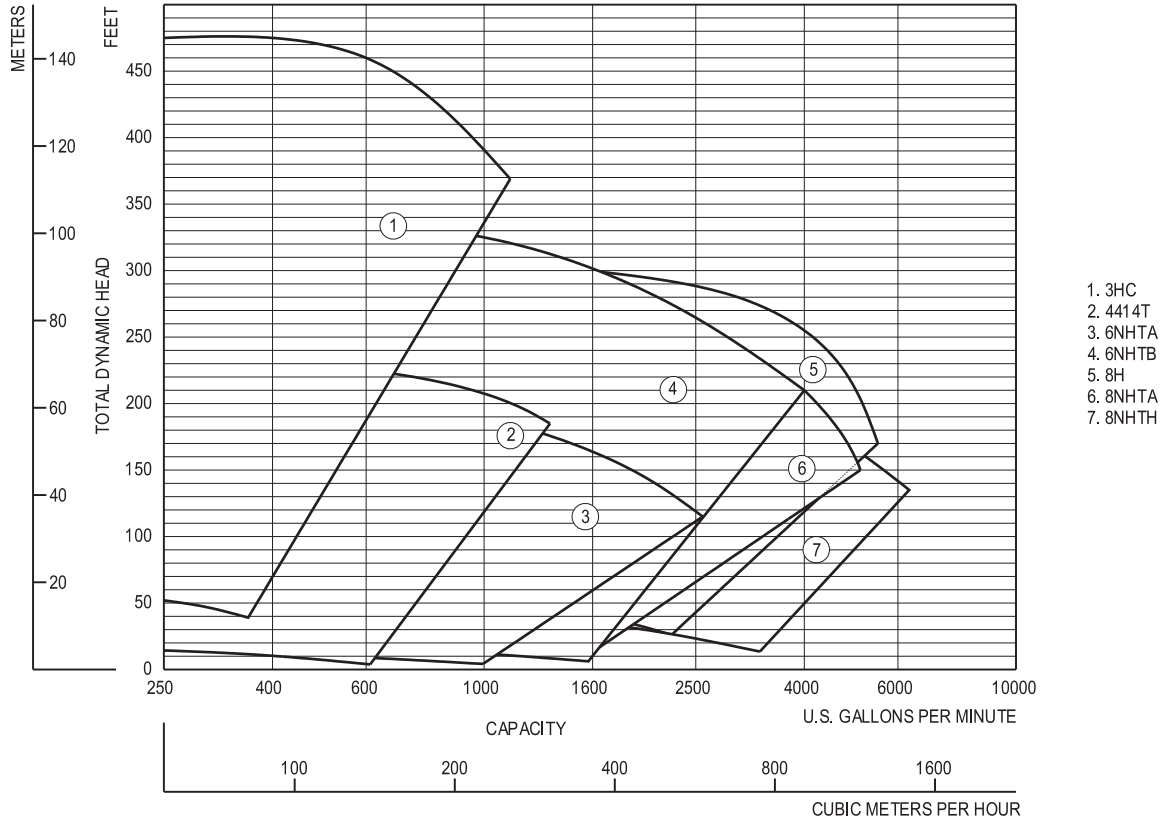

**MOST COMMON WATER TRANSFER FAMILY MAP**

## CHARACTERISTICS AND OPTIONS WITH MOST COMMON WATER TRANSFER PUMPS

- Replaceable wear rings
- Double volute
- External balance line
- Fully machined impellers
- Heavy-walled castings
- Replaceable shaft sleeves
- Various Mounting Configurations
- Shower curtain shield
- High efficiency
- High Suction Lift
- Two-year warranty
- Oversized bearings
- Minimum 20,000 hrs bearing life
- Patented Cycloseal® design
- Low cost of repair
- High efficiency
- Lower operating cost

## THICKER, SLEEVED SHAFTS

The Alloy steel shaft is more than 25% thicker than most other competitors. This allows the shaft to work under greater stress and still perform well. The sleeved shaft, prevents materials from flowing back into the pump, and prolongs the shaft and seal life. Sleeves are standard on Cornell Pumps—if available from a competitor, they are often expensive options. 420HT sleeve shafts available for abrasive materials.

## SILICON-CARBIDE SEAL

Externally lubricated mechanical seal is standard. Seal can be run dry on high vacuum even when pumping highly abrasive materials.



# FRACKING PUMPS

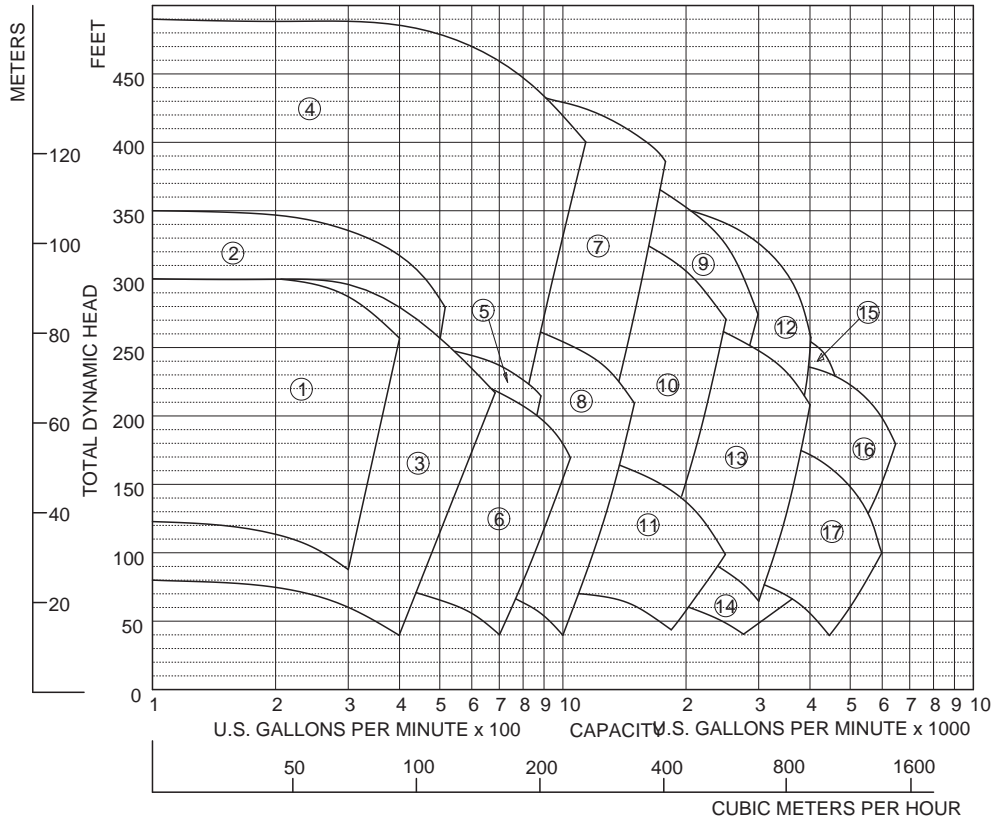

### MODEL

- 1. 2.5RB
- 2. 2.5H
- 3. 2.5YH
- 4. 3HC/HA
- 5. 3RC/RB
- 6. 3YL/YH
- 7. 4HC
- 8. 4RC/RB
- 9. 5HH
- 10. 5RC
- 11. 5YBH
- 12. 6HH
- 13. 6RC/RB
- 14. 6YB
- 15. 8H
- 16. 10RB
- 17. 10YB

### OTHER CLEAR LIQUID FAMILY MAP

Additional family maps available at [cornellpump.com](http://cornellpump.com)



## HYDRAULIC SUBMERSIBLE PUMPS

Cornell's DuraSub™ uses a heavy duty pump end and bearing frame for direct coupling to a hydraulic motor. The DuraSub™ has a modular design which allows standard Cornell pump ends to be used as a Hydraulic submersible pump.

- Available for most Cornell pump models
- Hydraulic motor driven
- Various adapter plates available for hydraulic motor fit
- Heavy duty shaft / bearing frame assembly and wet end construction
- Premium wet end efficiencies reduce horsepower requirements
- Heavy duty pumps ends for long service life and reliability



## WET PRIME

Cornell's line of horizontal self-priming centrifugal pumps are equipped with semi-open impellers for handling liquids containing solids in suspension. These pumps can operate satisfactorily with liquids containing air or dissolved gases. Various materials of construction are available for the Wet-Priming pumps: all iron, all stainless steel, all bronze, stainless steel fitted and bronze fitted.

## SUBMERSIBLES HIGH EFFICIENCY

Cornell uses the same high efficiency pump-ends for our submersibles that have been proven time and time again in standard municipal applications. Coupled with the highest quality motors, Cornell's submersible product line provides the best possible value. The bottom line — Cornell Submersible Pumps cost less to operate.

At Cornell we understand the need for reliability, durability and efficiency. This is why we have coupled our pumps with the most reliable and durable submersible motors on the market. Cornell motors are FM approved and suitable for Class I, Division I, Group C & D, explosion proof service and are inverter duty. Non-wicking, Permanently numbered leads are potted into a separate cable cap assembly, preventing leakage to the stator. Cornell motors are protected by thermostats and utilize class F insulation. Dual moisture probes are installed for the early detection of seal failure.

Capacities from 80 GPM to 15,000 GPM and heads from 10 feet to 400 feet give Cornell a clear performance advantage.

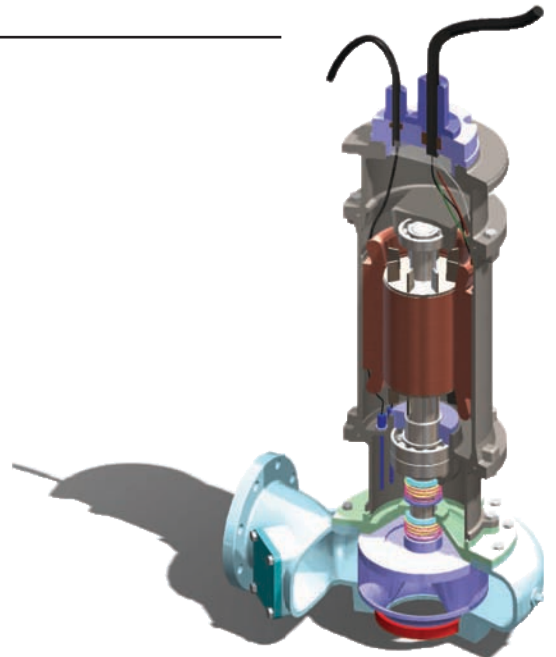

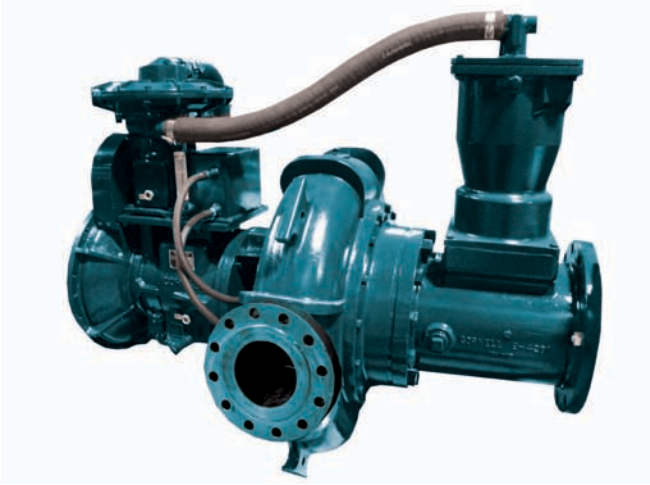

## SOLIDS HANDLING IMPELLER OPTIONS

Cornell's two- and three-port enclosed impellers are designed to handle large solids and maintain exceptional hydraulic efficiencies. Cornell's Delta™ style impeller is specifically designed for handling stringy materials and heavy sludge for low- to medium-head applications. The three- or four-vane, semi-open impeller generates a cutting action designed to handle concentrated slurries for high head applications.



## REDI-PRIME®

Cornell Redi-Prime® pumps are designed with oversized suctions to provide more flow, reduced friction losses, and higher suction lift. The priming system was designed with the environment in mind. By using a positive sealing float box and a diaphragm vacuum pump, there is no water carry-over to contaminate the environment. With suction lifts of up to 28 feet, heads to 470 feet and flow rates exceeding 20,000 GPM, most Cornell pumps can be readily fitted with the Redi-Prime® system.

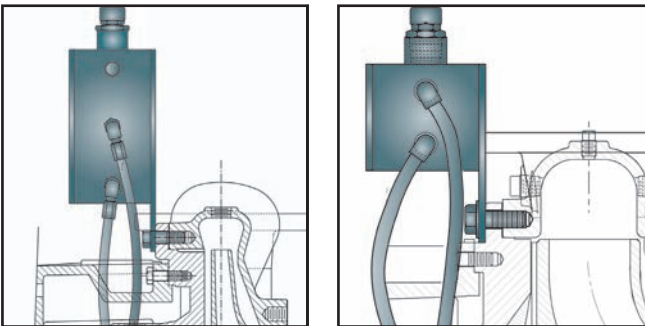

## RUN-DRY™ OPTION

Run your pump dry without the use of expensive water systems and without mechanical seal damage. Cornell's Run-Dry™ system consists of an auxiliary gland which provides containment for an application-specific lubricant present at the inside diameter of the mechanical seal faces. This lubricant prevents dry running of the seal faces while priming, re-priming, and on standby. The Run-Dry™ gland is connected to a lubricant reservoir via inlet and outlet lines which are oriented tangentially to the pump shaft so that shaft rotation provides circulation and subsequent cooling of the lubricant.

## MOUNTING CONFIGURATIONS

Cornell's Modular Frame design allows for easy adaptability. Choose a pump, then pick the mounting configuration best suited to your application. Right hand and left hand rotation along with tangential or centerline discharges are available for most pumps.

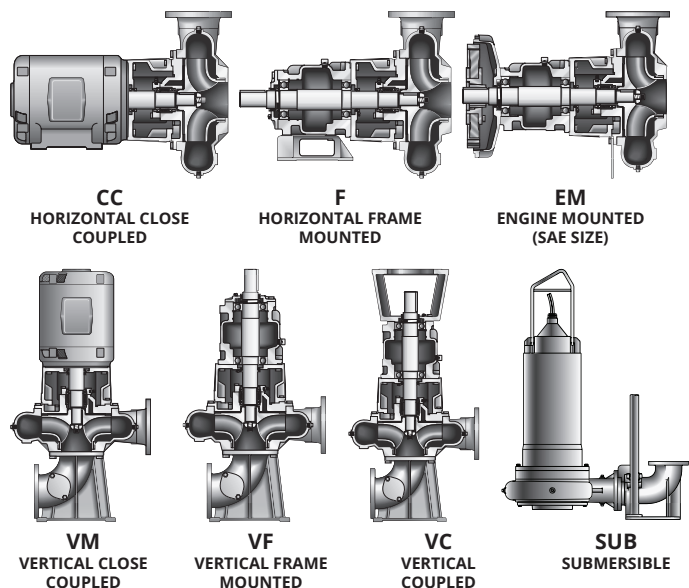



# MARKET AND PRODUCT LINE



AGRICULTURAL



FOOD PROCESS



INDUSTRIAL

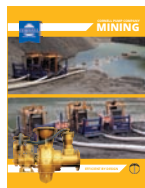

MINE DEWATERING



MUNICIPAL

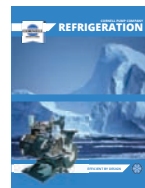

REFRIGERATION

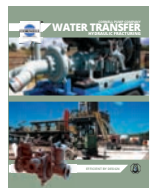

WATER TRANSFER



CHOPPER



CUTTER



EDGE™



HYDRAULIC SUBS



HYDRO TURBINE



IMMERSIBLE



MANURE



MP SERIES



MX SERIES



REDI-PRIME®



STX



SLURRY

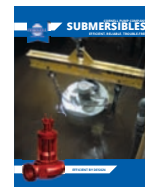

SUBMERSIBLE

Cycloseal®, and Redi-Prime® are Registered Trademarks of Cornell Pump Company.

Cornell pumps and products are the subject of one or more of the following U.S. and Foreign patents: 3,207,485; 3,282,226; 3,295,456; 3,301,191; 3,630,637; 3,663,117; 3,743,437; 4,335,886; 4,523,900; 5,489,187; 5,591,001; 6,074,554; 6,036,434; 6,079,958; 6,309,169; 2,320,742; 96/8140; 319,837; 918,534; 1,224,969; 2,232,735; 701,979 and are the subject of pending U.S. and Foreign Patent Applications.



Cornell Pump Company  
 16261 SE 130th Ave  
 Clackamas, OR 97015  
 P: (503) 653-0330  
 F: (503) 653-0338



**CORNELLPUMP.COM**  
 ©2013 CORNELL PUMP COMPANY